

Assembly Instructions

Step 1.

Snow Blade will mount on these four front types (Figure 1 through 4). Mounting is the same for all types past this step.

Locate and drill holes using front bracket (08) in front of caster support tube on zero turn tractor. Place front bracket (08) close to the end of the bar like shown. Works best when the bracket butts up against the weld of the caster bearing tube. **The maximum distance between the pins is 34.5 inches. Keep pins parallel to the tractor noted by the dotted line.** Mark holes and drill in the center of the caster support tube.

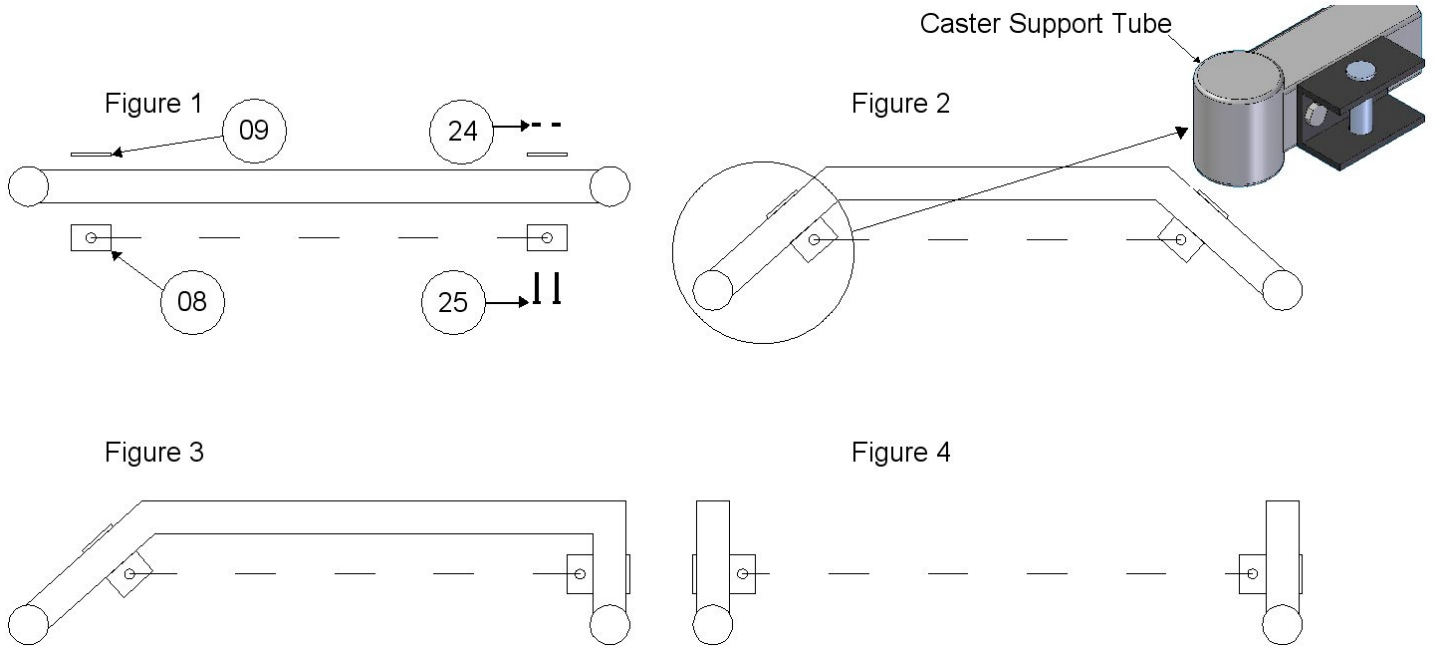

Step 2.

Secure front brackets (08) and back plates (09) as shown. Use bolts (24) and lock nuts (25).

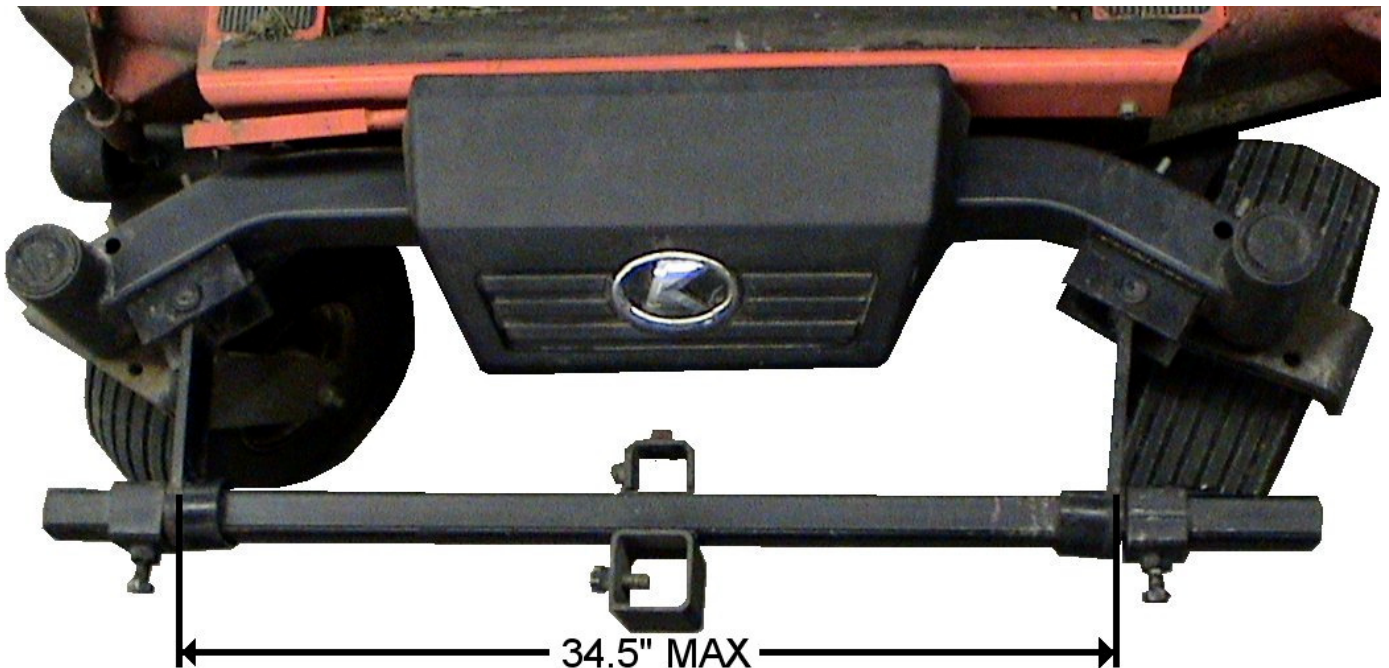

Step 3.
Place side supports (06) into front brackets (08). Secure with connector pins (19) and linch pins (26).

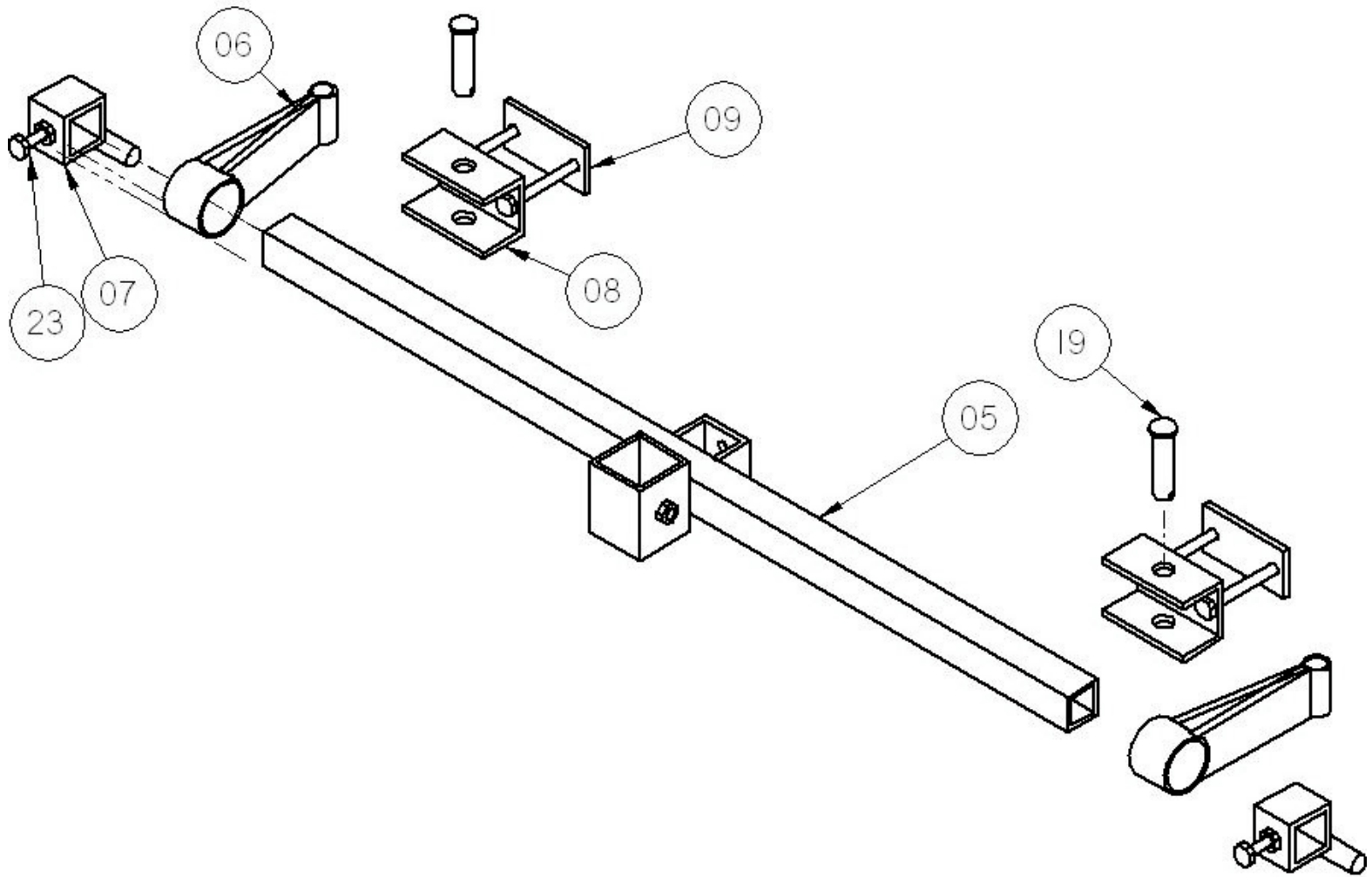

Slide universal mount (05) into support brackets (06).

Slide Anti-Rotate collar (07) onto ends of universal mount (05). Anti-rotate pins should rest underneath side support when center on universal mount (05) parallel to the ground.

Insert bolt (23) into collar (07) and loosely tighten. Repeat for opposite side.

See next page for finished picture.

Bolt on Kit

3"

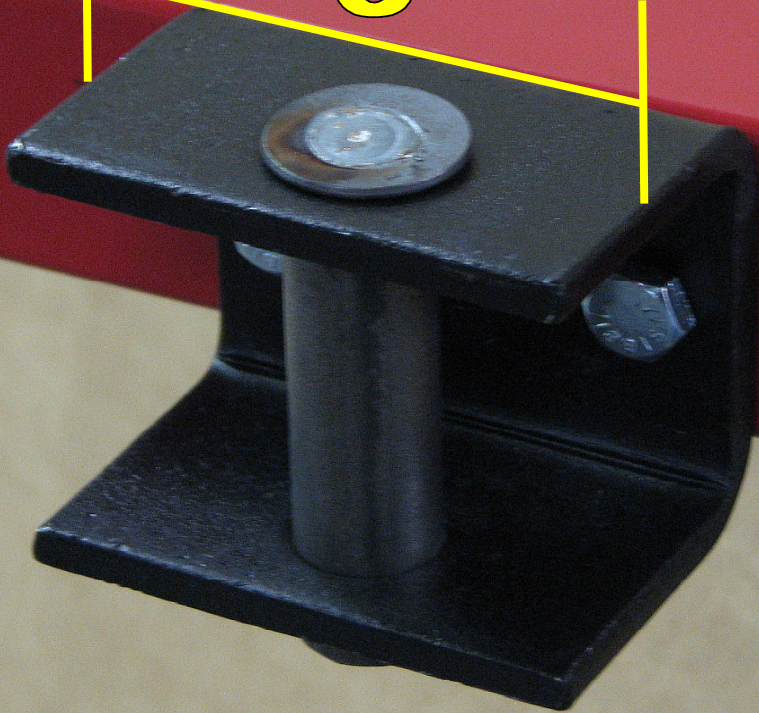

4"

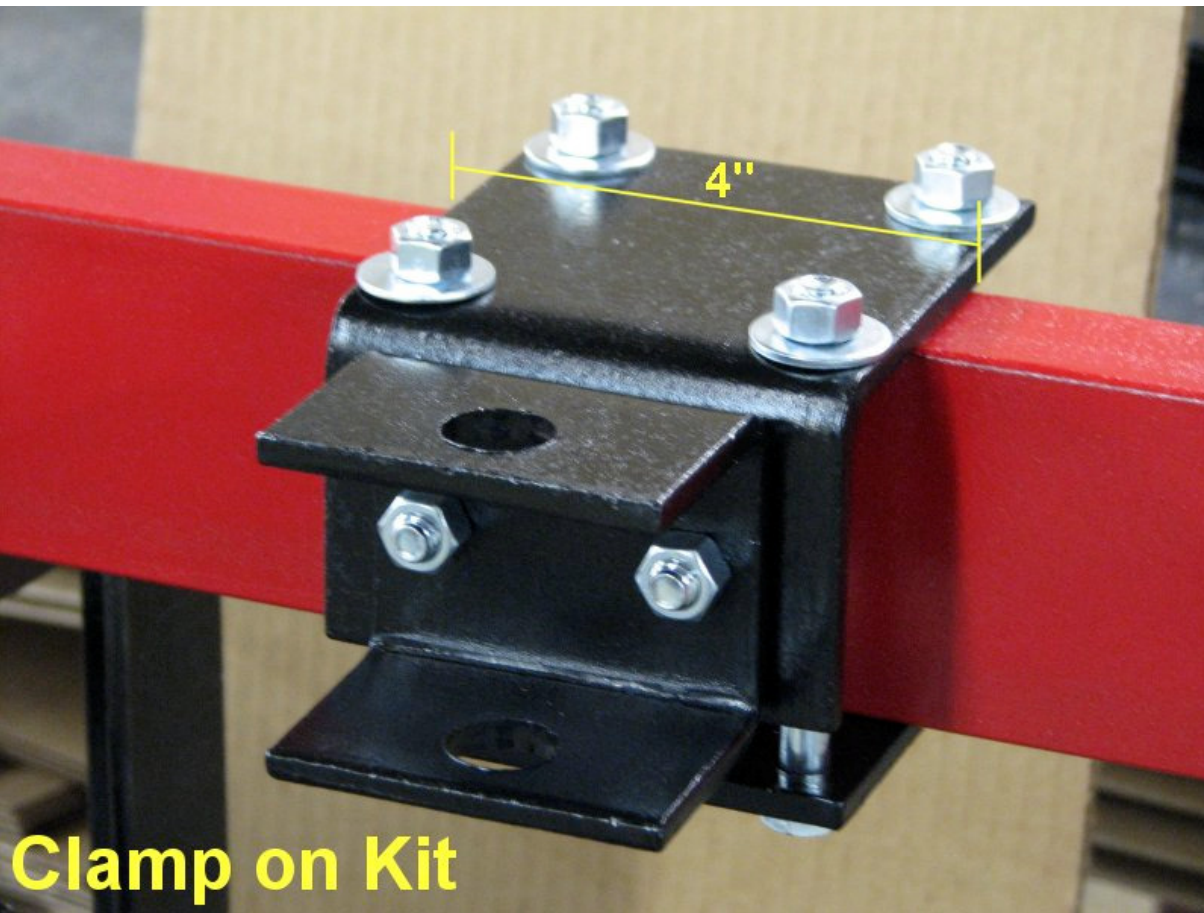

Clamp on Kit

Figure 5:

Step 4. Figure 5

Attach foot bar (10c) to foot lift (10) using bolt (27) and nut.

Insert foot lift into rear opening of universal mount (05). Then secure using bolt (23).

FOOT PEDAL ONLY USED FOR SNOW PLOW ASSEMBLY

